

Technical Data Sheet TI-F15 Locking Unit KB

For a detailed functional description refer to "Technical Information TI-F10".
Further important practical advice is given in "Assembly Instructions MA-F15".

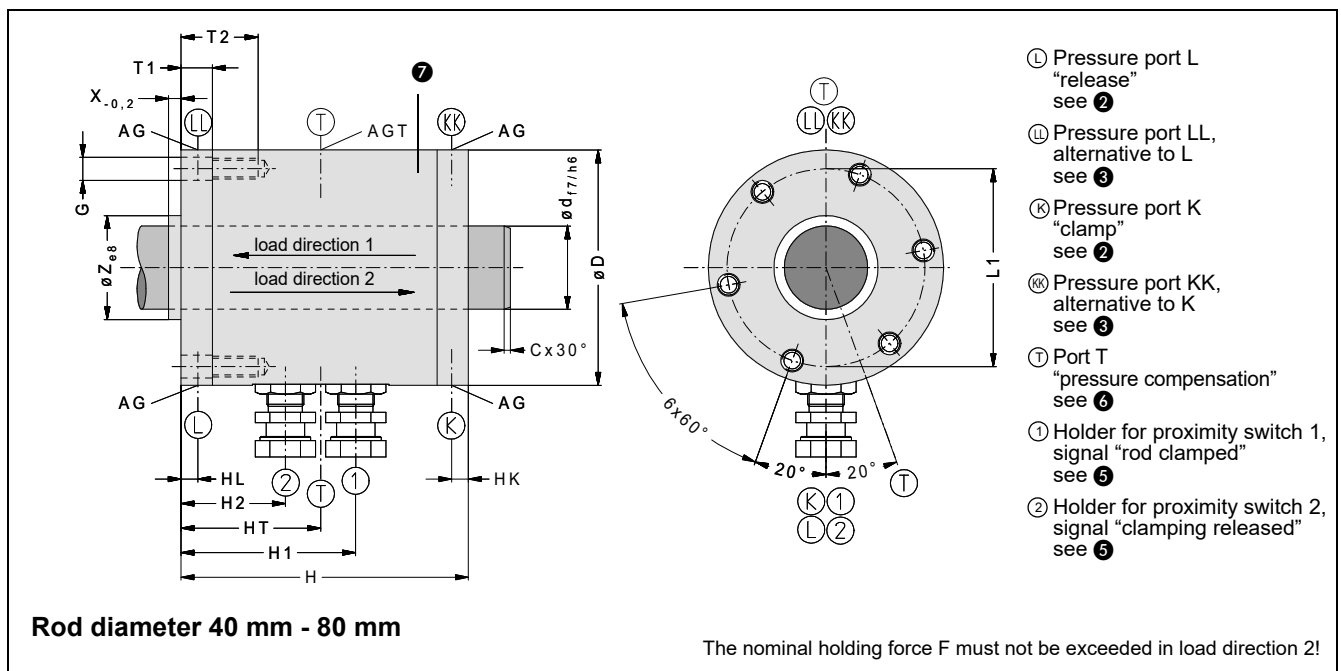

Fig. 1: Dimensions Locking Unit KB (CAD-files download at www.sitema.com)

Type	Ident.-No.	d	F	p	D	H	L1	T1	T2	Z	X	G	C	AG	AGT	HL/HK	V	H1	H2	HT	Weight
	(order no.)	mm	kN	bar	mm	mm	mm	mm	mm	mm	mm					mm	cm ³	mm	mm	mm	kg
KB 40	KB 040 10	40	80	130	138	193	118	20	45	52	3	M12	4	G1/4	G1/8	10	20	110.5	82.5	96.5	19
KB 56	KB 056 10	56	140	160	170	227	145	21.5	55.5	70	3	M16	4	G1/4	G1/8	11	40	127.5	99.5	113.5	33
KB 80	KB 080 10	80	210	160	226	266	190	30	65	100	4	M20	5	G3/8	G1/4	15	55	159	107	133	64

Subject to modification without prior notice

1 The nominal holding force F is the minimum holding force for dry or hydraulic-oil wetted rods. The nominal holding force F must not be exceeded in load direction 2.

The operating pressure p is the pressure required to secure the holding force F. The operating pressure p is the max. admissible operating pressure.

In case a holding force smaller than F is required a correspondingly proportional reduction of the pressure is favorable for the lifetime of the components.

It is convenient to use the same pressure for releasing as for clamping.

3 Plugged hydraulic ports LL and KK alternative to L and K, also useful for bleeding the pressure chambers.

4 Hydraulic operating volume

5 Proximity switch holders are provided for standard inductive proximity switches (M12 x 1 nominal switching distance 2 mm, flush mountable, NO (normally open)).

For easier service, the proximity switch holders have a depth stop and are pre-adjusted when delivered from the factory. The switches only need to be inserted to the stop and then clamped.

The proximity switches are not supplied in the standard scope of delivery, but are available as accessories.

6 Internal volume changes during switching are compensated at ports T. An air filter is fitted to one of the ports T for "breathing". The other port T is closed by a plug screw. In a dry and clean factory environment, this offers sufficient protection against dust etc.

If, however, moisture or aggressive media are present, a pressure-less hose instead of the filter must be installed to connect the Locking Unit KB with clean atmosphere (e.g. a clean pressureless container). The other port T must be sealed with a plug screw.

7 The surface of the housing parts is primed black, the mounting side is treated with corrosion protection wax.

Technical Data Sheet TI-F15 Locking Unit KB

For a detailed functional description refer to "Technical Information TI-F10".
Further important practical advice is given in "Assembly Instructions MA-F15".

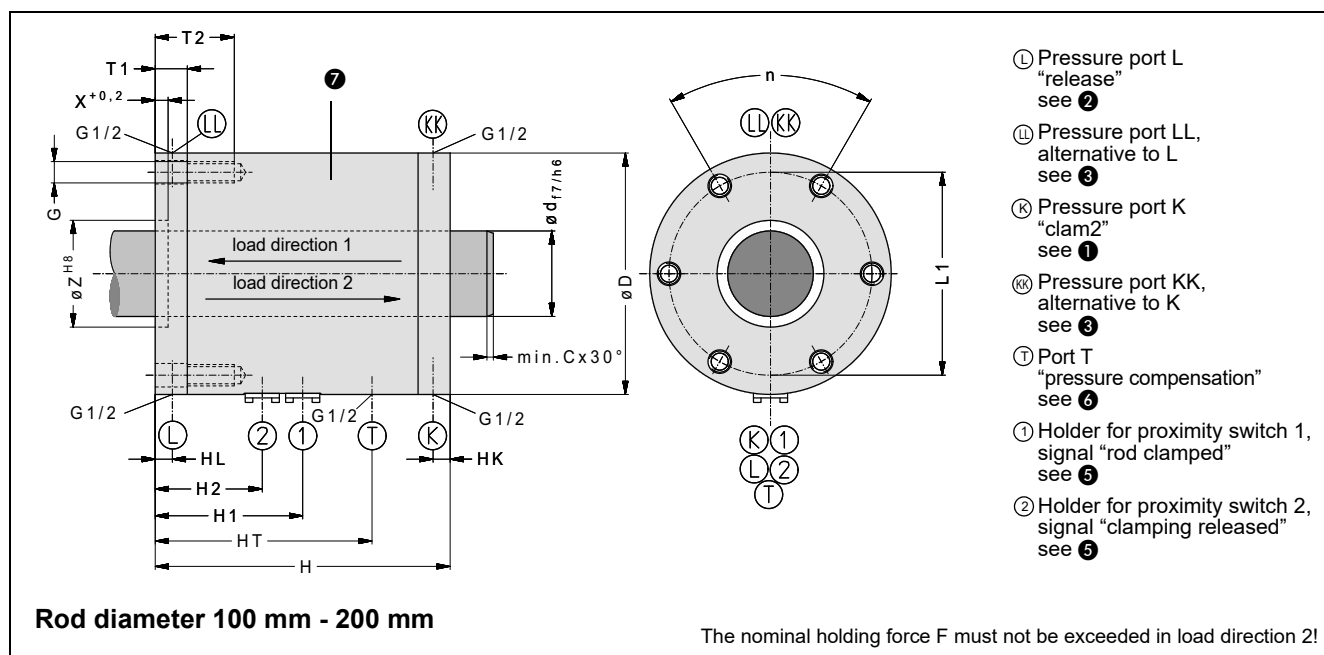

Fig. 2: Dimensions Locking Unit KB (CAD-files download at www.sitema.com)

Type	Ident.-No.	d	F	p	D	H	L1	T1	T2	Z	X	n	G	C	HL	HK	V	H1	H2	HT	Weight
	(order no.)	mm	kN	bar	mm	mm	mm	mm	mm	mm	mm				mm	mm	cm ³	mm	mm	mm	ca. kg
KB 100	SK 100 059	100	330	130	280	322	240	44	90	140	10	6x60°	M24	5	25	25	110	174	122	215	130
KB 110	SK 110 032	110	450	130	300	344	260	44	90	180	10	6x60°	M24	5	25	25	180	185	133	226	151
KB 125	SK 125 034	125	450	130	300	344	260	44	90	180	10	6x60°	M24	5	25	25	180	185	133	226	145
KB 140	SK 140 030	140	600	130	335	392	290	50	100	230	10	6x60°	M30	5	30	30	220	200	148	255	210
KB 160	SK 160 021	160	800	130	375	402	330	50	100	270	15	6x60°	M30	5	30	30	300	200	148	260	260
KB 180	SK 180 013	180	950	130	405	434	360	50	100	290	15	8x45°	M30	5	30	30	380	206	154	270	320
KB 200	SK 200 013	200	1100	130	425	444	380	50	100	310	15	8x45°	M30	7	30	30	450	248	196	300	382
KB 200	KB 200 10	200	1500	140	455	544	400	70	120	300	15	12x30°	M30	7	50	40	500	380	328	184	523

Special sizes, delivery time on request

Subject to modification without prior notice

① The nominal holding force F is the minimum holding force for dry or hydraulic-oil wetted rods. The nominal holding force F must not be exceeded in load direction 2!

② The operating pressure p is the pressure required to secure the holding force F. The permissible working pressure is 140 bar.

In case a holding force smaller than F is required a correspondingly proportional reduction of the pressure is favorable for the lifetime of the components.

It is convenient to use the same pressure for releasing as for clamping.

③ Plugged hydraulic ports LL and KK alternative to L and K, also useful for bleeding the pressure chambers.

④ Hydraulic operating volume

⑤ Proximity switch holders are provided for standard inductive proximity switches (M12 x 1 nominal switching distance 2 mm, flush mountable, NO (normally open)).

The proximity switches are not supplied in the standard scope of delivery, but are available as accessories.

⑥ Internal volume changes during switching are compensated at port T. It is plugged with an air filter which, in a dry and clean factory environment, offers sufficient protection against dust etc. If, however, moisture or aggressive media are present, a pressureless hose instead of the filter must be installed to connect the Locking Unit KB with clean atmosphere (e.g. a clean pressureless container).

⑦ The surface of the housing parts is primed black, the mounting side is treated with corrosion protection wax.

Purpose

The Locking Unit KB is used as an infinitely variable lock on piston rods for cylinders or other clamping rods. The Locking Unit KB absorbs axial forces in both load directions.

Axial play

The load is held free from axial play in load direction 1.

The load is also free from axial play in load direction 2 as long as the load does not exceed 80 % (from KB 110 approx. 50 %) of the nominal holding force F. In the case of exceeding, the axial play in load direction 2 is about 0.1 - 0.3 mm.

Operating conditions

The Locking Unit KB is designed to operate in normal clean and dry workshop atmosphere.

Operation in other environmental conditions is possible if at least port T is connected to a clean and dry atmosphere (e.g. tank). In case of heavy soiling conditions (grinding dust, chips, other liquids, etc.), please contact SITEMA.

Viscous lubricants and grease may reduce the holding force. The permitted surface temperature is -20°C to +60°C.

Choosing the right size

The tables on page 1 and 2 show the nominal holding force F of the various types. The value of F must be higher than the maximum axial load acting on the rod.

Braking is not allowed. In case of doubt, please contact SITEMA.

Design and attachment of the rod

The Locking Unit KB will operate correctly only if the rod has a suitable surface:

- ISO tolerance field f7 or h6
- induction hardened min. HRC 56, surface hardening depth:
 - ø up to 30 mm: min. 1 mm
 - ø over 30 mm: min. 1.5 mm
- surface roughness: Rz = 1 to 4 µm (Ra 0.15 - 0.3 µm)
- protection against corrosion, e.g. hard chromium plating: 20 ±10 µm, 800 – 1 000 HV
- lead-in chamfer, rounded:
 - ø 18 mm up to ø 80 mm: min. 4 x 30 °
 - ø over 80 mm up to ø 180 mm: min. 5 x 30 °
 - ø over 180 mm up to ø 380 mm: min. 7 x 30 °

Often, the following standard rods fulfill the above mentioned requirements and can then be used:

- piston rods (ISO tolerance field f7), hard chrome plated
- rods for linear ball bearings (ISO tolerance field h6)

The rod must not be lubricated with grease.

Pressure fluid

Hydraulic oil (HLP) in accordance with DIN 51524-2:2017 must be used as pressure fluid. Please consult SITEMA before using any other fluids.

Actuation

In most applications, an actuation as suggested in Fig. 3: „Schematic diagram of hydraulic circuit“ is used.

During every operational cycle, port L has to be pressurized via the 4/2-way valve to keep the Locking Unit KB released. Pressure port K is depressurized.

To clamp, pressure at port L is released, and port K is pressurized.

If the hydraulic pressure fails, a gradual but rather unpredictable release of the clamping force is to be expected.

The Locking Unit KB should only be actuated when the rod is stopped.

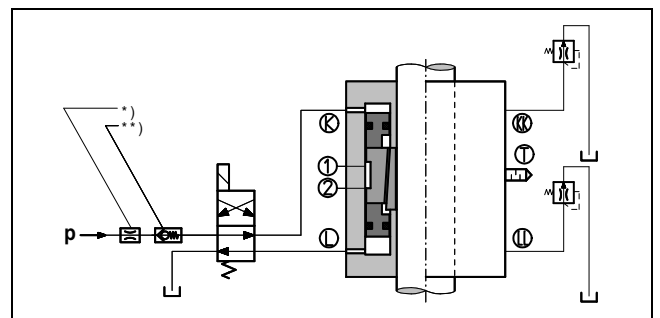

Fig. 3: Schematic diagram of hydraulic circuit

- * In case impact noises due to excess pressure are audible when pressurizing the Locking Unit KB, these can be suppressed by means of a flow control valve in the p-line.
- ** In case the pressure is not sufficiently constant (e.g. pressure drop at the beginning of a downward stroke), we recommend a check valve in the p-connection of the valve.

If a particular quick response time of the Locking Unit KB is required, the following preconditions must be met:

- short line distances
- fast valve response times
- appropriate control
- large valve and line cross-sections

Regular functional checks

The Locking Unit KB must be functionally checked at regular intervals. Regular checking is the only way to ensure that the Locking Unit KB will safely operate in the long term.

Please see "Assembly Instructions MA-F15" for further details.

Maintenance

Maintenance is limited to the regular test of the holding force as prescribed above.

To ensure the correct function, any repair or refurbishing must be carried out by SITEMA.

SITEMA cannot take any responsibility for repairs by another party.